

FMS165Z-H系列 超高性能平移台

FMS165Z-H Ultra High Performance Stage

FMS165Z-150H FMS165Z-200H
FMS165Z-250H FMS165Z-300H

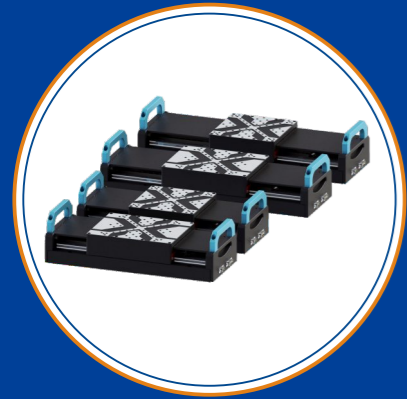

- 行程覆盖
150mm、200mm、250mm与300mm
- 最小步进距离可达50纳米
可超慢速稳定运行
- 高达5纳米分辨率的光栅尺编码器
反馈能以亚微米的可重复定位精度进行精确定位
- 超静音位移台
适用于实验室环境与高性能要求的工业场所
- 拖链内置,方便线束管理
- 免费标准版SDK
Window、Linux环境下支持多种开发语言:C/C++、C#、Matlab、LabVIEW等
- 高性能控制器
实现圆弧插补,直线插补,位置记忆任意图形导入
- 可选配EtherCAT总线控制

产品应用 APPLICATION FIELDS

- 工业CT Industrial CT
- 飞秒加工 Femtosecond processing
- 半导体 Semiconductor
- 显微扫描 Microscan
- 光纤延迟线 Fiber Delay Line
- 激光切割机 Laser Cutter
- 激光焊接机 Laser Welder
- 医疗 Medical
- 仪器设备制造
Equipment Manufacturing

产品简介 OVERVIEW

电动运动平台同时具有高精度特性、高速能力、超低速运行能力、高稳定性是非常困难的。2022年,菲克科技专门为复杂科研应用开发了旗舰系列产品FMS165Z-H超高性能平移台。FMS165Z-H解决了超低速运行稳定性难题,采用超高分辨率光栅尺配合超高精度装配工艺,使该系列平移台有极佳的超低速运行能力并达到亚 μm 级重复定位精度。FMS165Z-H采用内置拖链,方便线束管理,结合Feinixs高性能版本的FMC04-H系列控制器,能完美呈现高性能版本控制器的所有高级功能,运行速度最高可达1m/s。

It is very difficult for electric motion stage to have the performance of high precision, high speed, super low speed and high stability at the same time. In 2022, Feinixs developed its flagship product series, THE FMS165Z-H ultra-high performance stages, specifically designed for complex scientific research applications. FMS165Z-H solve the problem of ultra-low speed operation stability. It equipped with ultra-high resolution grating ruler and ultra-high precision assembly process to make the series stages have excellent ultra-low speed operation ability and achieve sub- μm level of repeated positioning accuracy. FMS165Z-H equipped with built-in tow chain for convenient wire harness management. Combined with the FMC04-H series controller of Feinixs high performance version, it can perfectly present all advanced functions of the high performance version controller. The operating speed is up to 1m/s, close to the theoretical limit of the maximum speed of short travel motor stage.

设计细节 FEATURES

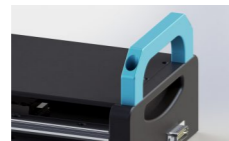

新颖的提手设计
助您快速便捷的调整位置



标配耐磨静音拖链
拖链内置,方便布线

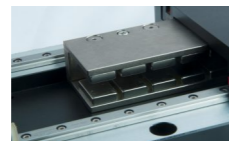

进口超高精度直线导轨
精磨安装底面
精准定位的保证



镀金空心针接口
确保电气连接万无一失



进口高品质有铁芯直线电机
大推力,运行平顺

组合搭配 TYPICAL ASSEMBLY



产品参数 SPECIFICATIONS

Model	FMS165Z-150H	FMS165Z-200H	FMS165Z-250H	FMS165Z-300H
行程 Travel (mm)	150	200	250	300
负载 Load Capacity(Kg)[1]	40	20	40	20
分辨率 Resolution (μm)	0.02	0.02	0.02	0.02
最小步进量 Min. Incremental Motion(μm)[2]	0.1	0.1	0.1	0.1
单向重复定位精度/保证值 Undirection Repeatability[3]/Guaranteed(μm)[4]	± 0.2 or 0.4	± 0.2 or 0.4	± 0.2 or 0.4	± 0.2 or 0.4
单向重复定位精度/典型值 Undirection Repeatability/Typical(μm)	± 0.1 or 0.2	± 0.1 or 0.2	± 0.1 or 0.2	± 0.1 or 0.2
双向重复定位精度/保证值 Bi-Directional Repeatability/Guaranteed(μm)	± 0.3 or 0.6	± 0.3 or 0.6	± 0.3 or 0.6	± 0.3 or 0.6
双向重复定位精度/典型值 Bi-Directional Repeatability/Typical(μm)	± 0.2 or 0.4	± 0.2 or 0.4	± 0.2 or 0.4	± 0.2 or 0.4
定位精度/保证值 Accuracy[3]/Guaranteed(μm)	± 1 or 2	± 1 or 2	± 1 or 2	± 1 or 2
定位精度/典型值 Accuracy/Typical(μm)	± 0.5 or 1	± 0.5 or 1	± 0.5 or 1	± 0.5 or 1
最大速度 Max. Speed (mm/s)[5]	500	500	500	500
直线度 Straightness(μm)	5	5	5	5
平整度 Flatness(μm)	5	5	5	5
偏摆 Yaw(arcsec)	15	15	15	15
俯仰 Pitch (arcsec)	15	15	15	15
持续推力 Continuous Force (N)	58	29	58	29
峰值推力 Peak Force (N)	200	100	200	100
重量 Weight(kg)	13.5	13	18	17.5

※ 备注

[1]:水平放置下的中心垂直负载

[2]:最小运动增量不等同于分辨率,最小运动增量是指运动系统在连续、稳定情况下能够移动的最小量。一般来说,系统分辨率远小于最小运动增量。考虑传动结构和编码器对系统误差的影响,直线电机位移台与步进电机位移台相比,其最小运动增量更加接近于分辨率

[3]:精度测量数据是平台在水平放置的情况下使用激光干涉仪测量的数据,测量标准参照GB/T17421-2000

[4]:典型值和保证值的区别见技术指南

[5]:最大速度为典型值,根据负载和控制器的不同会有区别

相关产品 RELATED PRODUCTS



FMS165Z-H系列 超高性能平移台

FMS165Z-H Ultra High Performance Stage

FMS165Z-150H FMS165Z-200H
FMS165Z-250H FMS165Z-300H



性能实测 ERROR CURVE

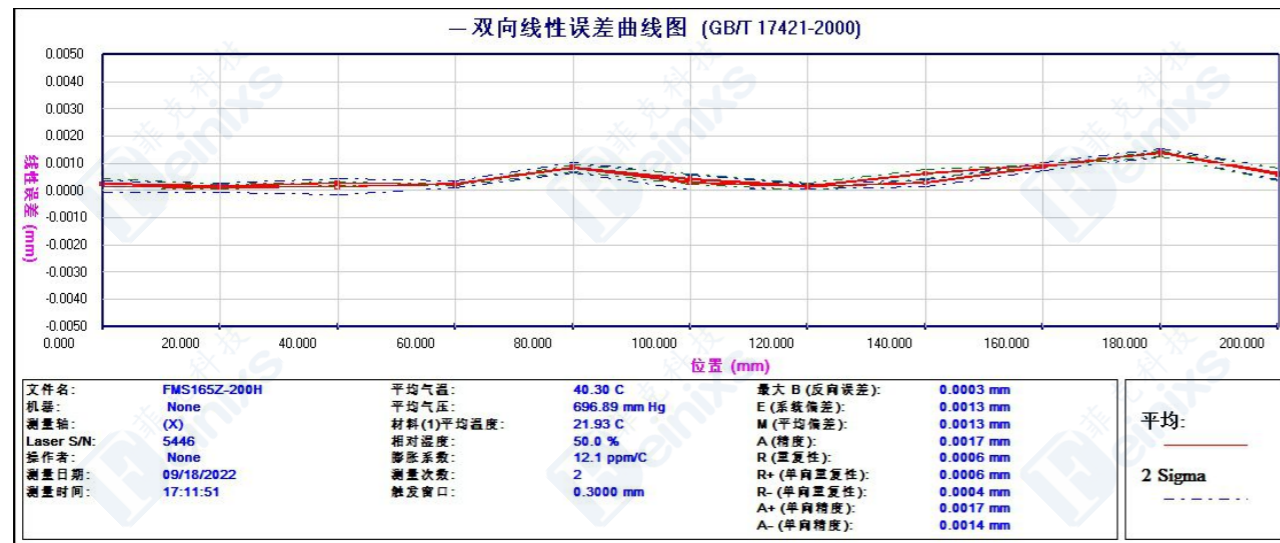

Each Stage is Tested with a Laser Interferometer. Product Identification and Traceability.

接线定义 HARDWARE CONNECTION

电机接口 Motor wiring diagram

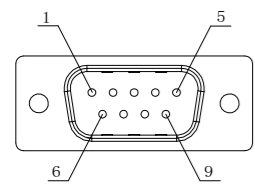

DB9公头

针脚	定义
1	U
2	/
3	V
4	/
5	W
6	/
7	PE
8	/
9	/

反馈接口 Encoder wiring diagram

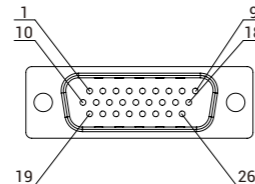

DB26公头

针脚	定义	针脚	定义
1	5V+	14	HC
2	0V	15	sin+
3	A+	16	sin-
4	A-	17	cos+
5	B+	18	cos-
6	B-	19	24V+
7	Z+	20	左限位
8	Z-	21	右限位
9	/	22	24V-
10	/	23	/
11	/	24	/
12	HA	25	/
13	HB	26	/

产品图纸 DIMENSIONS

FMS165Z-150H

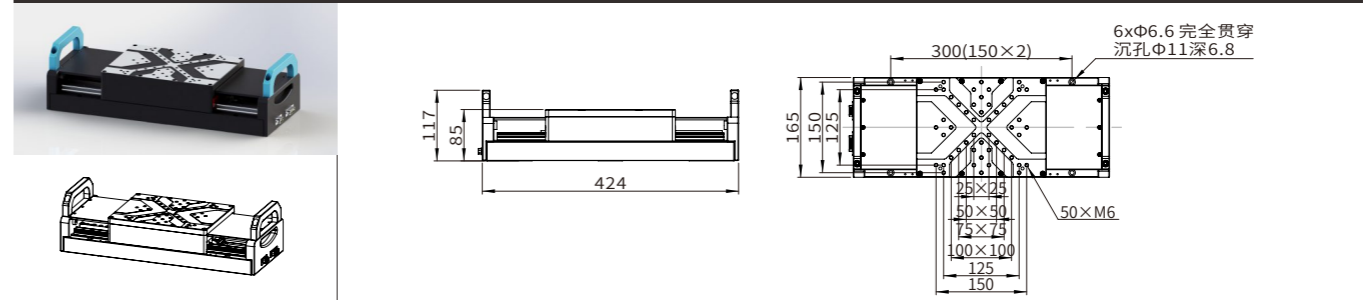

FMS165Z-200H

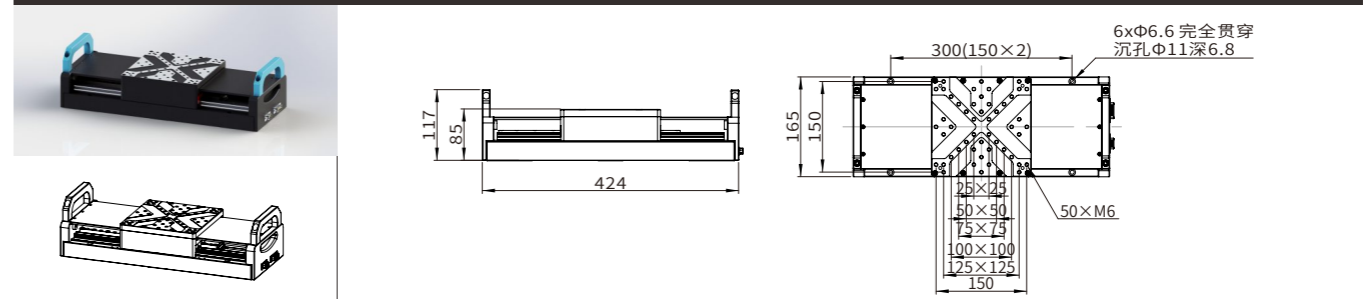

FMS165Z-250H

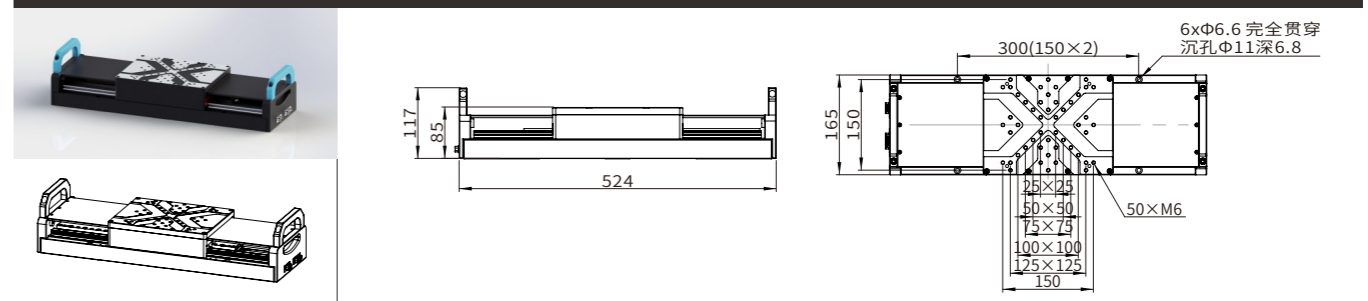

FMS165Z-300H

